



# THREE CHUCK AUTOMATIC FIBER LASER TUBE CUTTING MACHINE

3000W/6000W/8000W/12000W/20000W

$\phi 10 \sim 245 \text{mm}$  Cutting Diameter



Zero tailing cutting



High precision  
High efficiency



Bevel Cutting  
Easy to Operate



Bearing capacity is  
high Solid and stable

# THREE CHUCK AUTOMATIC FIBER LASER TUBE CUTTING MACHINE

Three-chuck fiber laser tube cutting machine is equipped with medium to high power fiber laser source from 3000W to 20000W. Supported by the coordinated three-chuck system, it achieves genuine zero tail material cutting, effectively reducing waste and cutting production costs.

The three-chuck structure delivers higher cutting accuracy and wider processing range, capable of handling complex cutting tasks. Optional bevel cutting ensures smooth and clean cutting edges, perfectly matching various welding requirements and eliminating the need for secondary grinding and finishing.

It is suitable for round tubes, square tubes, rectangular tubes and various metal profiles. Featuring easy operation, it fully meets the demands of high-precision, zero-waste and complex tube cutting processing.

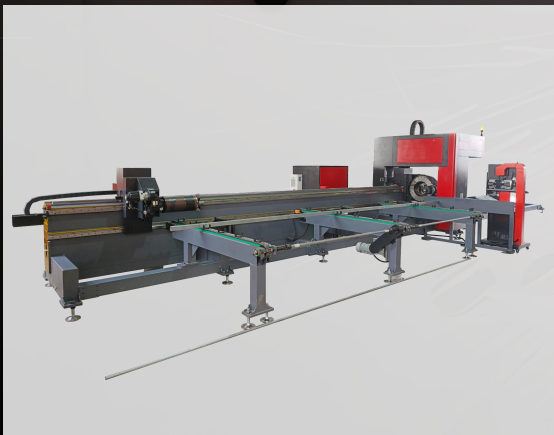

## SELLING POINT

### ✓ **HIGH PRECISION, MATERIAL-SAVING & WELD-READY**

A professional laser tube cutting machine that achieves high precision, zero waste or complex cutting. Precision cutting enables direct welding, reducing secondary grinding.

### ✓ **COMPATIBLE WITH MULTIPLE MATERIALS & TUBE TYPES**

Ideal for cutting cs, ss, copper, aluminum alloy tubes( square, round, oval, and special-shaped tubes), profiles, and other metal tubes.

### ✓ **THREE-CHUCK DESIGN, NO GEAR ADJUSTMENT FOR TUBE SIZES**

Triple-chuck system with the second and third chucks feature full-stroke capability, eliminating gear adjustments when switching between large and small tubes.

### ✓ **CROSS-CHUCK CUTTING, ZERO MATERIAL WASTE**

The cutting head can cross the center chuck and cut in the other direction, realizing really zero scrap, improving material utilization.

### ✓ **AUTOMATIC LOADING & FEEDING OF TUBES**

Automatically completes the loading, feeding and reaching the chuck clamping position of a single tube.

# CONFIGURATION

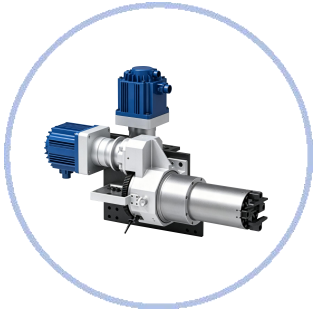

Rear Chuck



Fiber Laser Generator  
(Raycus/MAX/IPG )

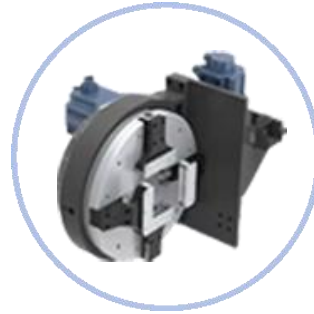

Middle Chuck

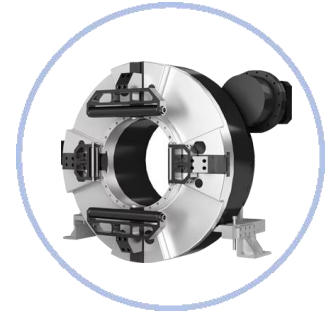

Front Chuck

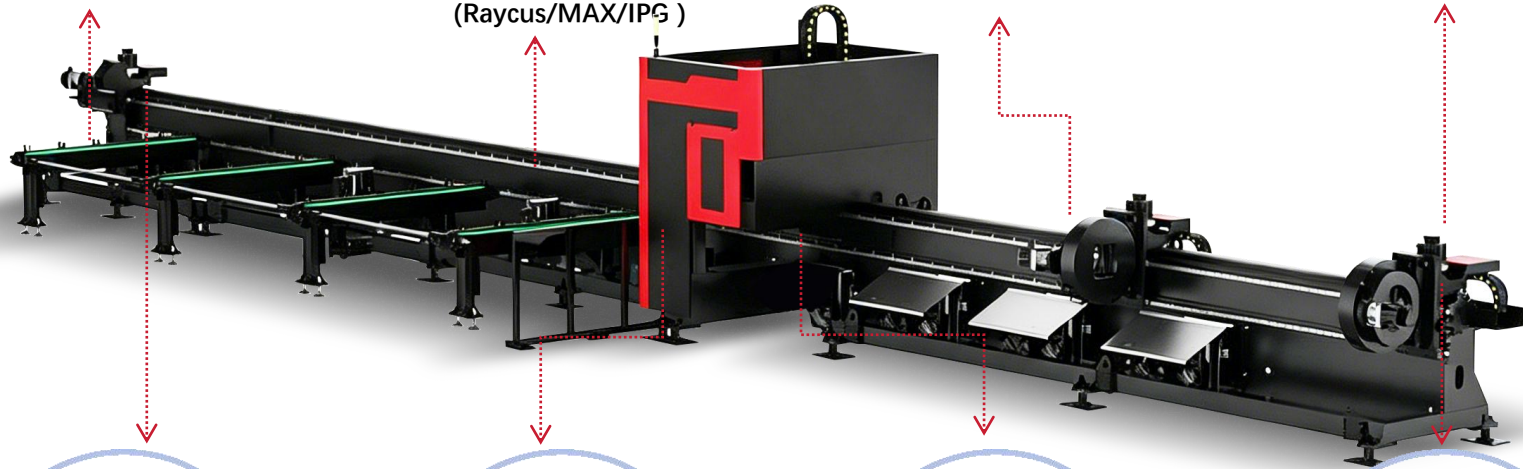

Japan Shimpo  
Reducer

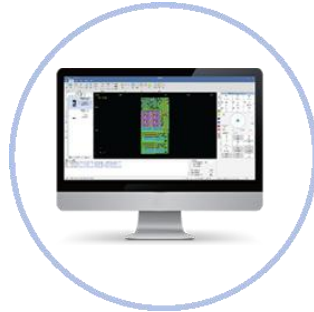

BOCHU Control  
System

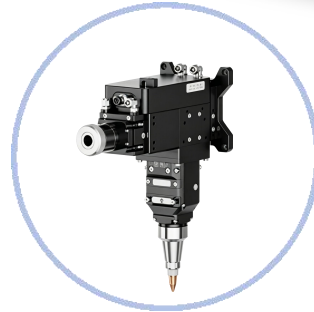

BOCI Laser Head



Servo Motor Driver  
(Delta/Fuji /Yaskawa)

# PARAMETER

Chuck Size	245mm
Loading Length	6000mm
Tail Material Length	Zero tailing
Unloading Length	6000mm
Chamfer Swing Angle	±45°
Chuck Over-travel	Three-chuck with offside function
Working Area	6000mm* φ10~245mm
Cooling System	Water Cooling
Laser Source	Raycus/MAX/IPG
Cutting Head	BOCI BLT510
Voltage	380V 3Ph, 50Hz
Linear Guide Rail	HIWIN Rails

# PARAMETER

<b>Rack and Gear</b>	<b>Taiwan YYC Rack</b>
<b>Servo Motors and Drives</b>	<b>Fuji/Yaskawa/Delta</b>
<b>Single tube support weight</b>	<b>300KG</b>
<b>Laser Power</b>	<b>3000W/6000W/8000W/12000W/20000W</b>
<b>Chiller</b>	<b>HanLi/S&amp;A</b>
<b>Maximum Speed Acceleration</b>	<b>1.5G</b>
<b>Repeat the rotation accuracy</b>	<b>±0.1mm</b>
<b>Positioning accuracy</b>	<b>±0.1mm/m</b>
<b>Max Speed of Chucks</b>	<b>100r/min</b>
<b>X/Y Position Accuracy</b>	<b>0.05m/min</b>

# PRODUCT SIZE

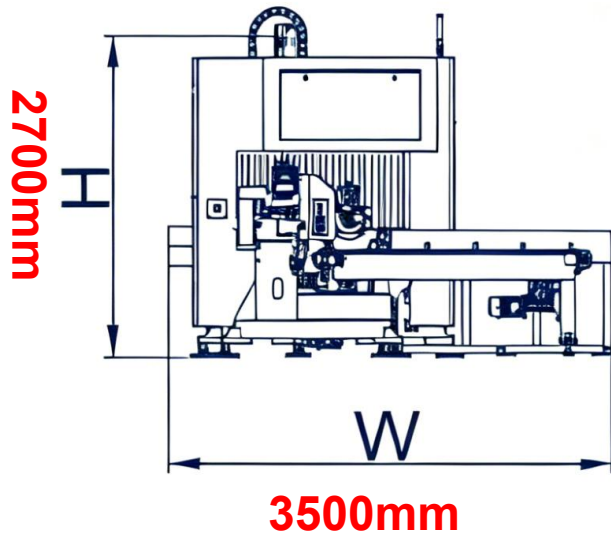
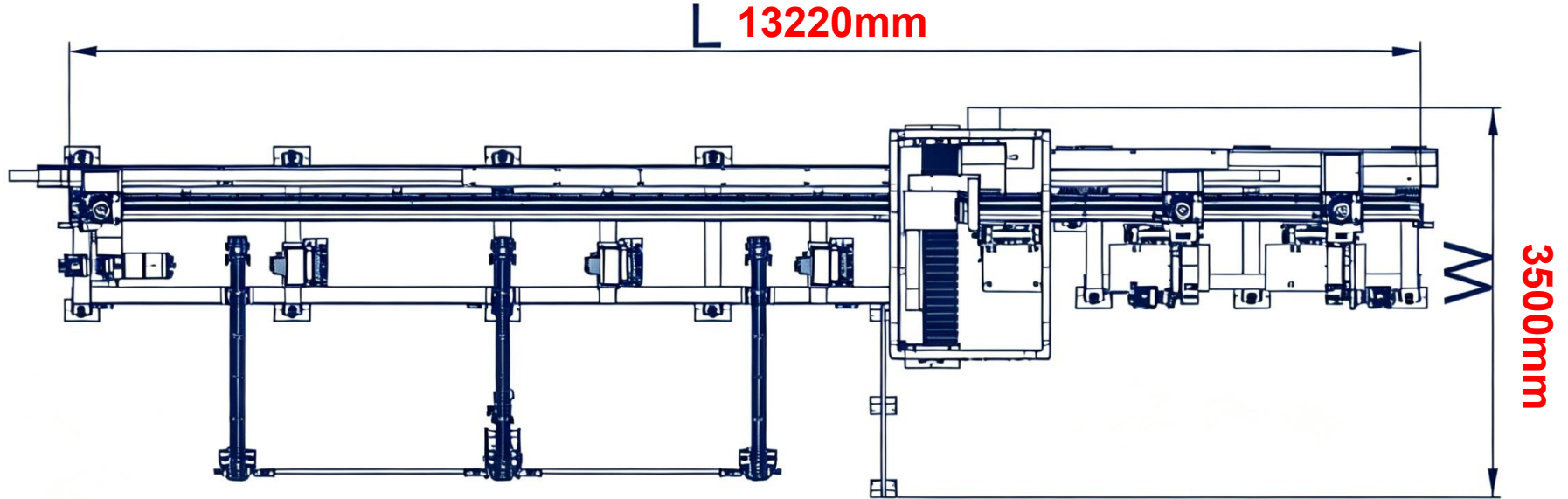

Model name	Chuck size	Length	Width	Height
FST-60245	245mm	13220mm	3500mm	2700mm

# LOADING RACK

It supports the loading of multiple tubes at once, and can store a large number of tubes on the rack, thereby significantly improving work efficiency. The automated intelligent feeding process greatly reduces the need for manpower and lowers labor costs.

- Modular split design
- Length measuring module
- Intelligent sorting
- Fully automated production
- Support a variety of tube

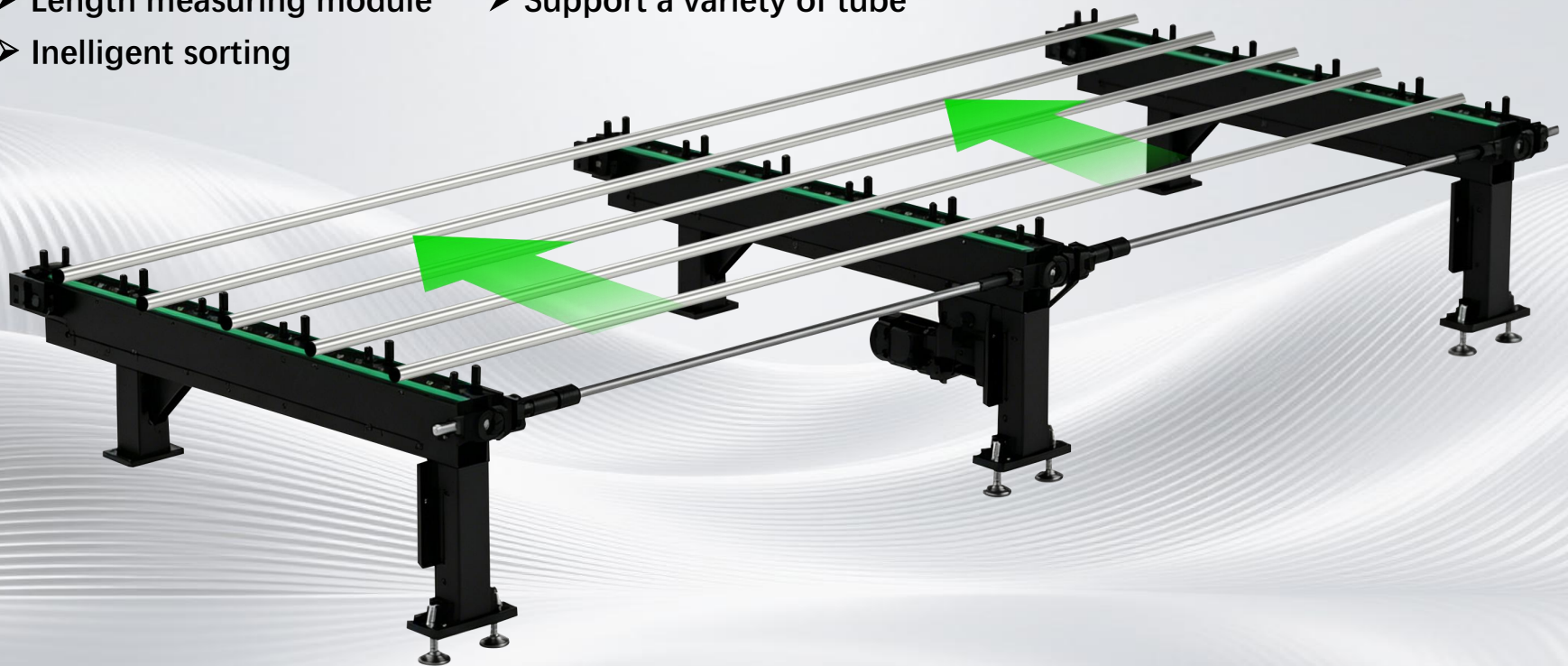

# UNLOADING RACK

A completely new servo-following die-cutting design has been adopted. During the cutting and unloading process, it can minimize the space for the workpiece to shake, further improving the cutting accuracy.

The fully automatic unloading does not require manual intervention, reducing labor costs.

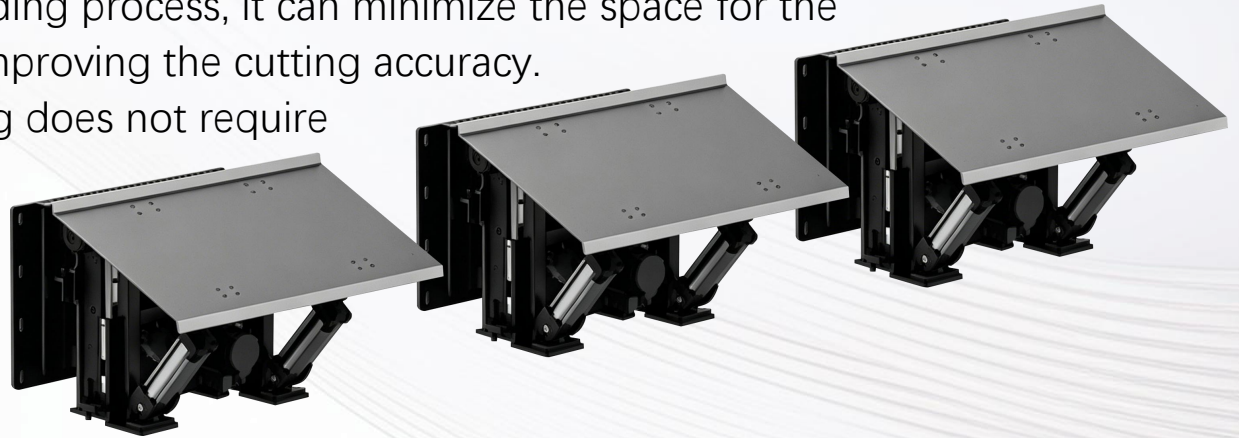

# SERVO MOTORS AND DRIVER

Imported Yaskawa, Fuji servo motors and drivers are adopted, featuring high precision, high speed, large torque, large inertia, stable and durable performance, which ensures the high speed and acceleration of the whole machine



# PNEUMATIC CHUCK



Full stroke pneumatic chucks with automatic centre adjustment for easy operation; Full stroke pneumatic chuck with built-in cylinder, easy to install, clamping and releasing by side air intake, suitable for clamping all tubes; Four-jaw guide and guide mechanical transmission, to achieve higher straightness and stability of the four jaws, true self-centring effect, without the need to adjust the position of the four jaws, thus greatly reducing the adjustment of the labour costs, improve productivity, stability and wear resistance.

## Efficiency

Rapid clamp release for greater stability

## Safety

Automated operation, low labour intensity

## Energy saving

Low energy consumption, no pollution

## Long life span

Simple structure durability

## LASER SOURCE

Adopting 3000W-20000W fibre laser sources from IPG, RAYCUS, MAX and BWT; the fibre laser sources have high photoelectric conversion efficiency and are equipped with optimized second-generation fibre optic transmission system for more stable beam quality and stronger resistance to high response; the cutting boards have a narrow kerf and a bright cross-section to ensure more stable and precise cutting results for thick plates



### Higher reliability

Higher single pulse energy

### Resists high inversion

Higher modulation frequency

### Maintenance free

Thin plate welding efficient

### Energy efficient

Longer life

# LASER CUTTING HEAD

BOCI fibre optic cutting head Automatic focusing; driven by imported motor, users can set up continuous focusing through the programme to complete the rapid perforation of thick plates and automatic cutting of plates of different thicknesses and materials; cartridge design to protect the lens for easy replacement.

## Design excellence

Improve cutting quality and efficiency

## Multi-protection

Effective protection of collimating lenses

## Automatic focusing

-12~+10mm

## Highly adaptable

Various mainstream laser source

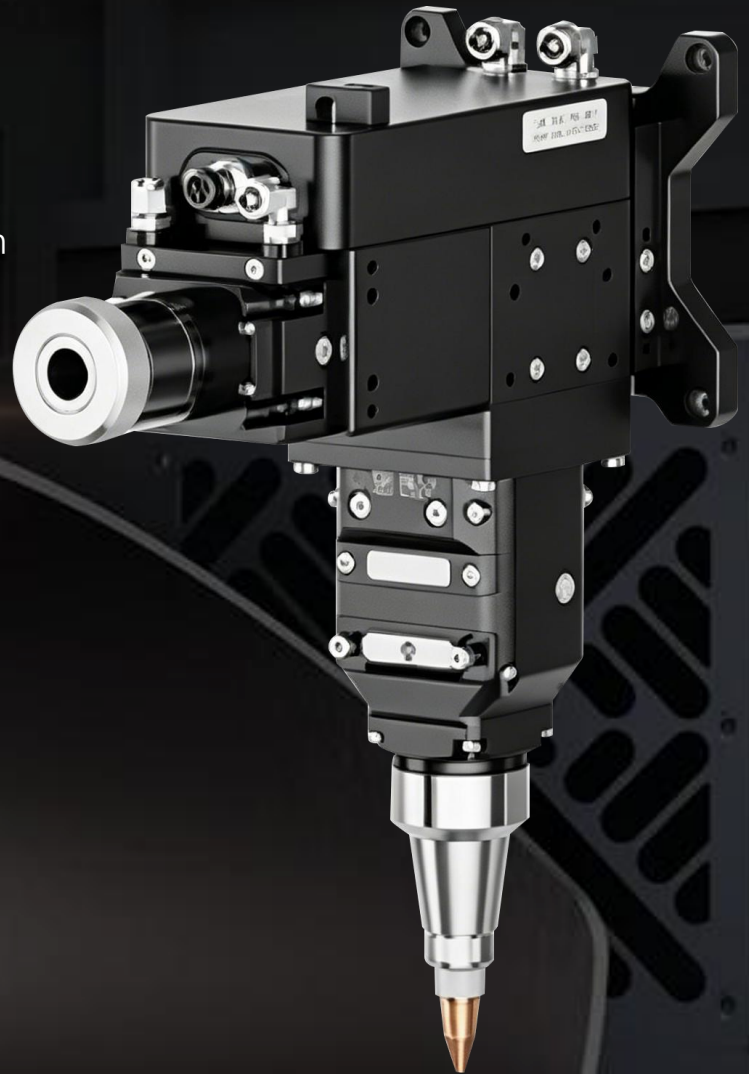

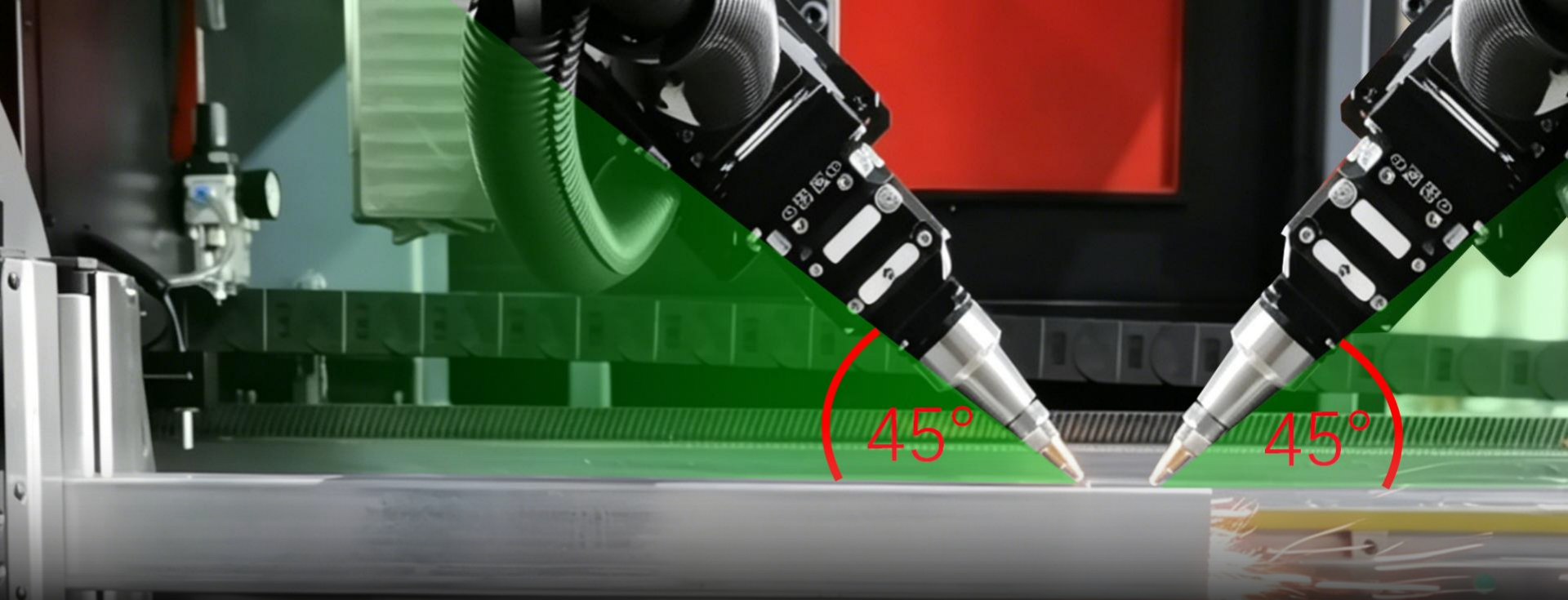

Y Bevel



X Bevel



V Bevel



K Bevel

## BEVEL CUTTING

- ☑ Supports  $\pm 45^\circ$  full-angle bevel cutting for all types of tubes.
- ☑ One-pass forming of V/Y/X/K bevels with zero tail material and no cutting blind spots.
- ☑ Smooth, precise and distortion-free cutting surface, no secondary grinding required.
- ☑ Ideal for high-precision welding in steel structure, machinery and tubeline industries.

# CAST ALUMINUM BEAM

Manufactured from aerospace aluminium, it is light in weight and has good dynamic performance; with the adoption of ultra-high-pressure tensile technology and lightweight design, its weight is reduced by 30% compared with cast aluminium beams, and its strength and stiffness are increased by more than 20%:

## Better material

Manufactured from aerospace aluminium

**-30%**

Reduced weight compared to cast aluminium

## Corrosion resistance

Resistant to corrosion and oxidation by chemical agents

**+20%**

Increased strength and stiffness



# HIGH STRENGTH SHEET BED

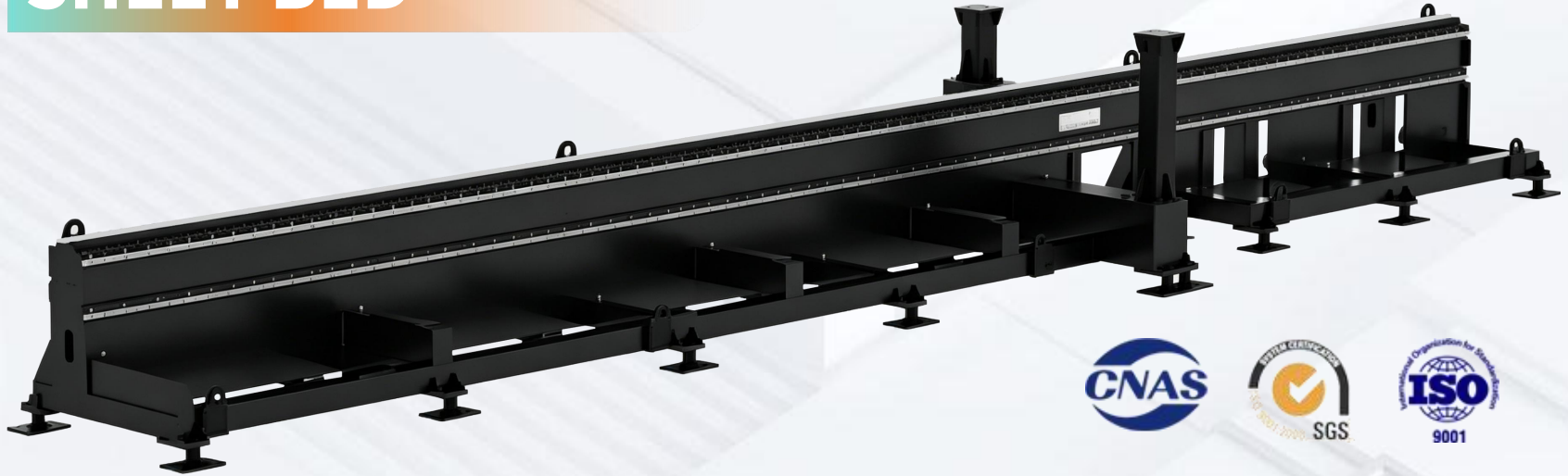

To meet high-speed operation requirements, the main bed is high-strength steel welded with two stress relief treatments, ensuring long-term accuracy, stability and superior rigidity. It adopts an integral high-strength plate welded bed, stable and durable. Bed high-temperature heat treatment and guide rail high-precision machining release internal stress and enhance deformation resistance.

Our self-developed high-low dual exchange platform complies with European standards, featuring fast switching speed, simple design and stable reliable performance.

## FOLLOW-UP SUPPORT DEVICE

Matching 3-chuck laser tube cutting machine, the follow-up support moves synchronously with cutting. It stably holds long, thick and special-shaped tubes, avoiding sagging, shaking and deformation. Ensures precise bevel and smooth cuts, ideal for long tube processing with stable accuracy.

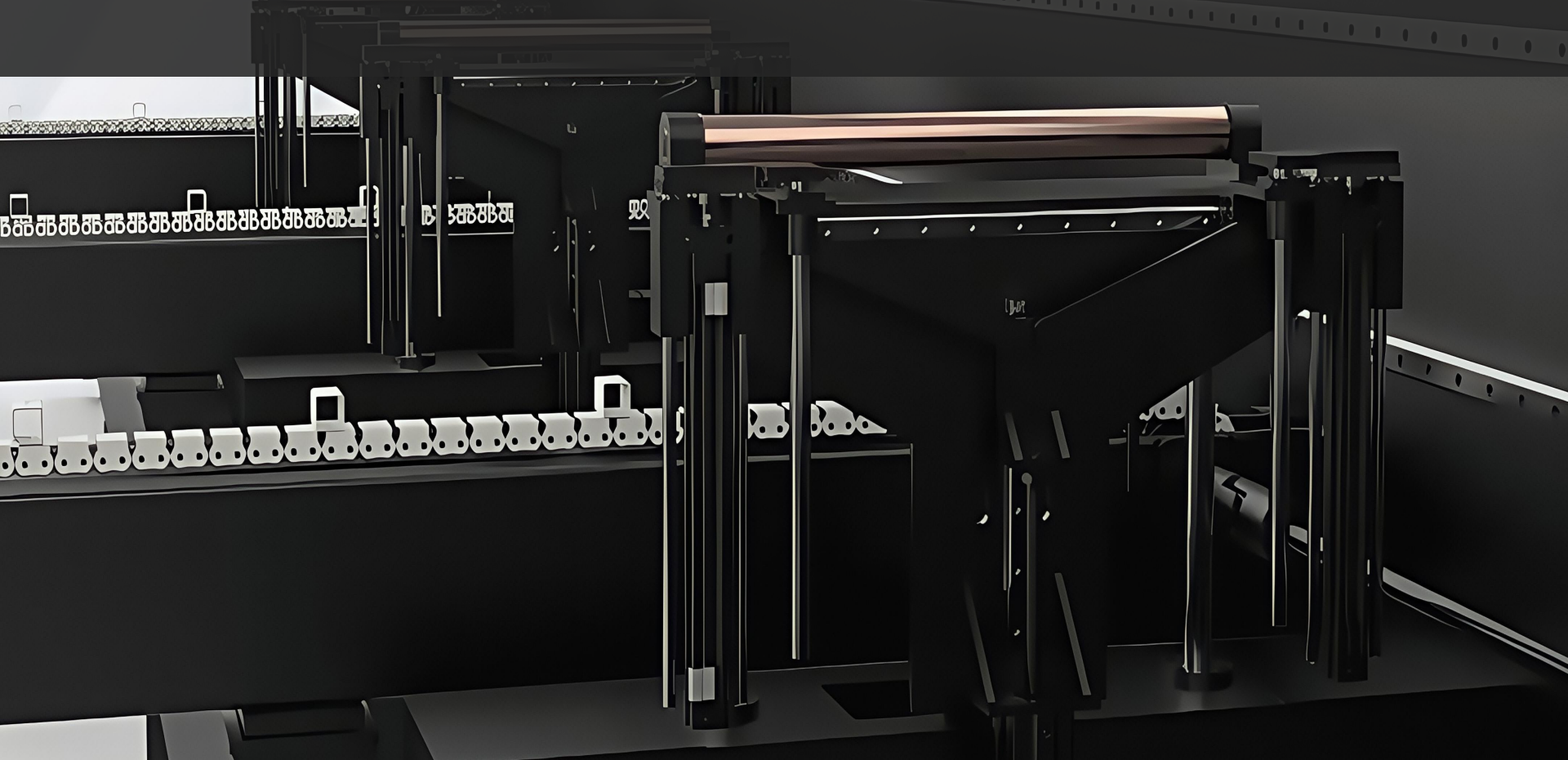

# FSCUT5000

## Field Bus System

- Excellent human-machine interaction and easy operation. Standard CNC program design makes it friendly and easy for new operators to get started quickly.
- Built-in rich process library and graphic database. Cutting parameters can be adjusted at any time, and graphics can be imported rapidly.
- Adopts fast and high-efficiency nesting algorithm to reduce material waste. There is no quantity limit for nesting plates.
- Optimized cutting path; multiple common-edge path generation modes are developed to adapt to different application scenarios.
- High precision, high speed, high follow-up performance and high intelligence level.
- Equipped with IO diagnosis function to quickly detect and locate equipment faults.

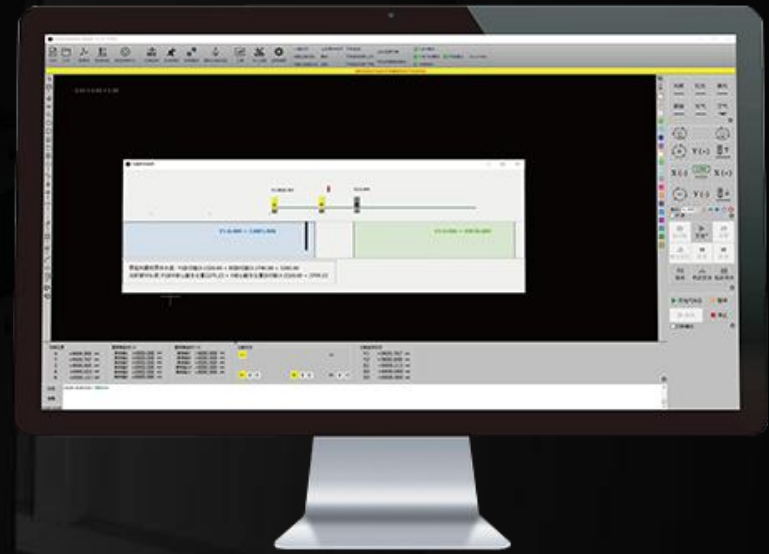



# TubestT

3D Tube Nesting Software

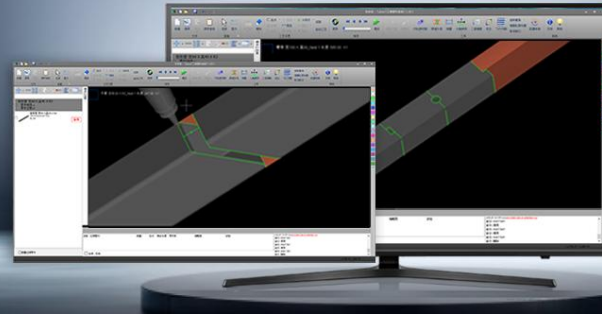

## TubestT

3D Tube Nesting Software

TubestT is a 3D tube nesting software designed for CypTube/TubePro laser cutting system. From parts drawing and modification, full type compensation, strategic nesting to report generation, using TubestT will meet and exceed your production needs.



# TubestT-Lite 三维套料软件

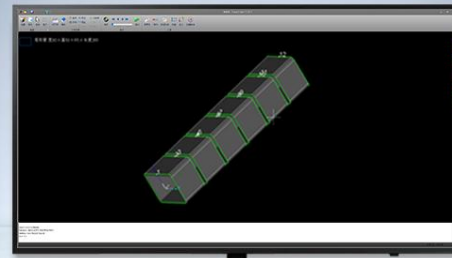

## TubestT-Lite

3D Tube Nesting Software

TubestT-Lite is a free software to generate toolpath for FSCUT tube cutting system. It's designed for CypTube/TubePro, can import part from external igs file, draw the part of standard shape and array-nest the part on the tube.



Support profiles of U/T/H/L shapes and free form shapes toolpath generation



## VOLTAGE STABILIZE

Stable voltage to ensure smooth operation of equipment.(Optional)



## AIR COMPRESSOR

It is a essential tool for cutting stainless steel and thin carbon steel materials. More cost saving.(Optional)



### 3 CHUCK tube CUTTING MACHINE

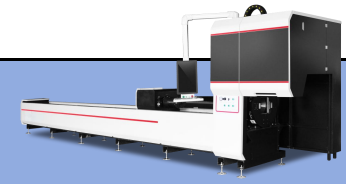

### 2 CHUCK tube CUTTING MACHINE

<p><b>SUPPORT STRUCTURE</b></p>	<p>The front, middle and rear three clamps are linked and support each other.</p>	<p>Double chuck clamping on both ends.</p>
<p><b>LONG TUBE PROCESSING</b></p>	<p>Full multi-point support, preventing tube sagging and ensuring smoother operation</p>	<p>Long tubes are prone to sagging and shaking, and their accuracy is likely to deviate.</p>
<p><b>CUTTING ACCURACY</b></p>	<p>High-precision positioning, with higher flatness of bevels and surfaces</p>	<p>The cutting error of the medium-long tube is relatively large.</p>
<p><b>LABOR COST</b></p>	<p>1 operator for 2-3 machines; fully automated process, no manual tailing intervention</p>	<p>1 operator for 1 machines; manual tailing handling and tube alignment required</p>
<p><b>MATERIAL UTILIZATION RATE</b></p>	<p>Zero tailing cutting</p>	<p>Tail length 200-300mm</p>
<p><b>PROCESSING EFFECT</b></p>	<p>Smooth cuts, standard bevels, no need for secondary grinding</p>	<p>Some conditions require a second adjustment.</p>
<p><b>OVERALL PRODUCTION EFFICIENCY</b></p>	<p>No downtime for tail handling; next tube feeds automatically for uninterrupted processing 80-200 pieces of 6m tubes per shift</p>	<p>Requires 1-2 minutes of downtime per tube for tail removal and reloading. 60-150 pieces of 6m tubes per shift</p>

# Intelligent Recognition

With contour recognition system, it can automatically identify standard round, oval, square and other special-shaped tubes.

Tubes realize non-inductive and high-efficiency detection, and realize the position deviation of the whole meter section's cutting accuracy within 0.15mm.



Angle

□ 15mm-165mm

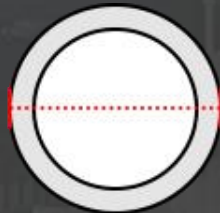

Round tube

□ 10mm-245mm

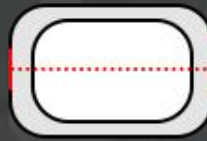

Rectangular

□ 15mm-165mm

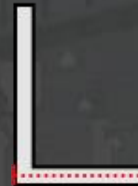

Angle

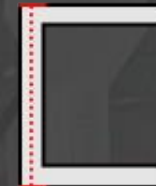

Channel



Other Shapes

Processing round tubes, square tubes, rectangular tubes Single tube load bearing up to 300kg.

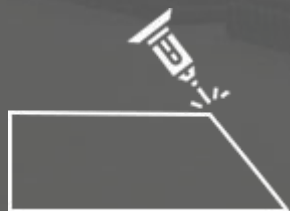

Bevel Cutting

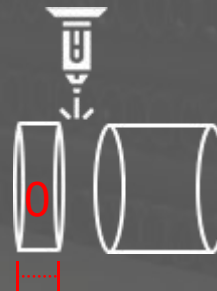

"0" tailing cutting

\* "Zero-tailing cutting" is industry-standard minimum tail technology. Subject to tube material and working conditions, absolute zero tail cannot be achieved.

## Applicable Materials:

Suitable for stainless steel, carbon steel, aluminum alloy, galvanized sheet and other metal materials.

## Applicable Industries:

Fiber laser cutting machines are widely used in the Construction & Steel Structure, Construction Machinery, Oil & Gas, Shipbuilding & Offshore Engineering, Automotive Manufacturing, Fitness Equipment, Agricultural Machinery, Power Engineering, and Rail Transportation industries.



# 10 YEARS PROFESSIONAL ODM/OEM MANUFACTURER OF LASER EQUIPMENT

30,000m<sup>2</sup>+

30,000-square-meter  
standardized workshop.

27+

We currently hold 27  
technical patents.

300+

We produce more than  
300 laser equipment  
every month.

4+

We own four separate  
trademarks.



天人合一  
以信为本  
用仁义道德实现企业可持续发展  
用我们的产品为顾客创造幸福

福斯特激光

以厚德 润天下

## Liaocheng Foster Laser Science & Technology Co., Ltd.

Liaocheng Foster Laser is a laser equipment company with over 20 years of technical experience, integrating R&D, production, sales and after-sales service. We focus on the manufacturing of laser equipment such as fiber laser tube cutting machines, flat laser cutting machines and laser welding machines. With a modern production base, our products have passed CE and other international certifications, exported to more than 60 countries worldwide, and won high recognition from customers at home and abroad for stable quality.

Our flagship three-chuck fiber laser tube cutting machine adopts a side-mounted triangular frame bed, featuring strong load-bearing capacity, high rigidity, stable operation and good shock resistance. Equipped with the latest pneumatic three-chuck, it supports independent clamping and opening, synchronous rotation and movement. Thanks to the unique chuck layout design, it truly achieves zero tail material cutting, greatly reducing raw material waste. Bevel cutting is optional, and no secondary processing is required for welding.

The equipment can be equipped with Raycus, Max, IPG laser sources with power ranging from 2000W to 12000W, matched with imported servo motors and precision transmission structures, ensuring high precision, fast speed and long-lasting stable performance.

It is equipped with a dedicated auto-focus cutting head and wireless handle control, supporting semi-automatic feeding and unloading, which is easy to operate. It can cut profiles such as round tubes, square tubes, angle steel and channel steel, and is suitable for materials such as carbon steel, stainless steel, aluminum alloy and galvanized sheet, widely used in automobile, shipbuilding and other industries. We always provide cost-effective laser tube processing solutions for global customers with high-quality equipment, professional technical support and comprehensive after-sales service.





## TRADEMARK

# 10+

United States

Mexico

Britain

Brazil

Italy

Germany

Foster Laser has successfully registered trademarks in 10+ countries, which means the company has obtained legal protection for trademarks in these countries. These registrations not only ensure exclusive use of the company's brand and prevent others from infringing or imitating it, but also provide strong support for the company's expansion in the international market.

## International Certification Shows Brand Strength

1. Strict Quality Control Standards

2. Authoritative Certification

3. Brand Guarantee



# PACKAGING

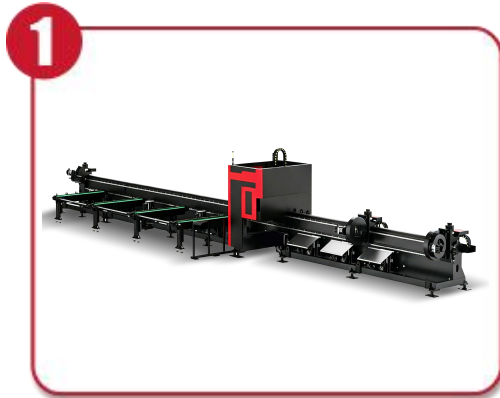

Machine cleaning and  
Protective oil processing



Wrapping with  
protective film



Forklift moving goods



Transportation



Container Sealing



Container loading

# EXHIBITION

Partners come from all over the world  
With 10 years of export experience





## **Q: What exactly does "0" tail cutting ?**

"0" tail material cutting refers to the process of tube cutting. Through the coordinated movement of the three-chuck system (linkage of front, middle and rear chucks), the material is fully utilized. When cutting the last section, it can still be accurately clamped and cut, achieving almost no waste residue, reducing material costs, and is especially suitable for high-value tubes or mass production scenarios

---

## **Q: What are the advantages of a three-chuck system?**

- 1.High material utilization rate: It can realize full utilization of materials with almost no waste residue, significantly reducing raw material costs, suitable for high-value tube processing scenarios.
  - 2.Wider processing range: The middle chuck works with the front and rear chucks to support complex cutting such as hollowing and patterns in the middle of tubes, without the need to adjust equipment additionally, breaking the operational limitations of the two-chuck system.
  - 3.Higher precision guarantee: It provides uniform clamping force during long tube processing, reducing tube bending and vibration, avoiding cutting deviations, and meeting the needs of mass and high-precision processing.
- 

## **Q: What is the bevel cutting angle?**

The bevel swing angle is  $\pm 45^\circ$ . It supports grooving, V-shape and Y-shape bevel cutting within  $50^\circ$ , with a cutting precision of  $\pm 0.03\text{mm}$ , ensuring optimal edge geometry for welding and assembly